

# OPÉRA

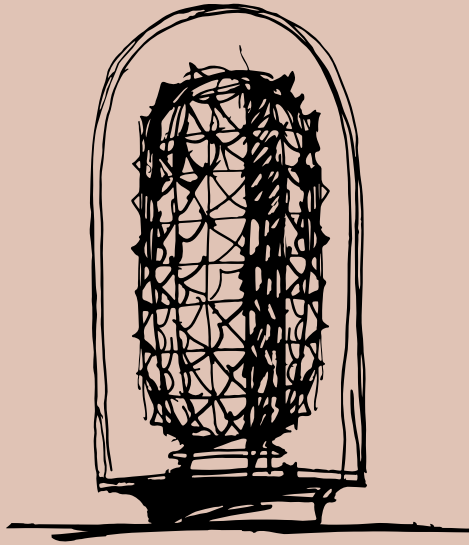

design

**philippe nigro**  
designer



## Barovier&Toso

VENEZIA 1295



L'estro di Philippe Nigro incontra la raffinata  
maestria artigianale e artistica dell'azienda.

*The flair of Philippe Nigro meets the refined  
skills and artistry of the company.*







Opéra porta la firma del designer francese Philippe Nigro ed è una collezione di lampade composta da sospensioni, applique e una versione da tavolo. Ispirata all'Opéra Garnier, si distingue per il suo carattere eclettico e decorativo, espresso da commistioni stilistiche e da uno spiccato equilibrio compositivo. L'opulenza e la grandiosità del rinomato teatro parigino, così come la sua struttura simmetrica, riecheggiano nel design delle lampade Opéra. Sottili i contrasti che animano la collezione.

I richiami ad una certa sontuosità barocca sono infatti smorzati da aspetti più minimali e contemporanei, a favore di un connubio delicato ed armonioso. La sfida progettuale era quella di valorizzare maestria artigianale ed heritage dell'azienda, da oltre sette secoli custode dell'arte del vetro. Frutto di questo lavoro creativo è un design senza tempo, elegante, ricco ma

*Opéra bears the signature of the French designer Philippe Nigro and it is a collection of lamps composed of suspensions, a wall sconce and a table version. Inspired by the Opéra Garnier, it stands out for its eclectic, decorative character, expressed in stylistic mixtures and remarkable compositional balance. The opulence and grandeur of the famous Parisian theatre, with its symmetrical structure, are echoed in the design of the Opéra lamps.*

*The collection thrives on subtle contrasts. The references to a certain Baroque splendour are tempered by more minimal, contemporary touches, generating a delicate, harmonious dichotomy. The design challenge was to bring out the artistry and heritage of the company, a repository of the art of glass for over seven centuries. The outcome of this creative effort*

non ridondante, dalla personalità diretta ed incisiva. L'elemento principale scelto da Nigro per connotare la collezione è la lavorazione del rostrato. Questa complessa tecnica artigianale, di cui Barovier&Toso detiene il brevetto, fu inventata da Ercole Barovier nel 1938 e consiste nel lavorare a mano "volante" (libera) il Cristallo Veneziano fino ad ottenere una serie continua di prismi sfaccettati. Affascinato da questa tecnica, e dal modo in cui il rostrato interagisce con la luce, Philippe Nigro ha realizzato un design che ne esalta le peculiarità. La forma cilindrica va infatti ad enfatizzare il motivo ornamentale, moltiplicando gli angoli di incidenza dei raggi luminosi e creando un fitto involuppo di punte tridimensionali. Alle creazioni in Cristallo Veneziano sono abbinati elementi metallici dalla silhouette molto affine, che circondano e sostengono i corpi luminosi:



*is a timeless, elegant design, rich but not redundant, with a direct, incisive personality. The main feature chosen by Nigro for the collection is the rostrato. This complex technique of craftsmanship, patented by Barovier&Toso, was invented by Ercole Barovier in 1938 and consists of "freehand" shaping of Venetian Crystal to obtain a continuous series of multi-faceted prisms. Fascinated by this process, and by the way the rostrato interacts with light, Philippe Nigro has formulated a design approach that enhances its particular character. The cylindrical form underscores the ornamental motif, multiplying the angles of impact of beams of light and creating a dense wrapping of three-dimensional points. The creations in Venetian Crystal are joined by metal parts with a very similar silhouette, which surround*







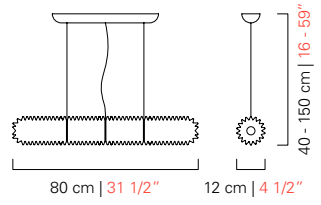
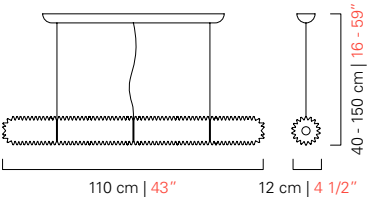

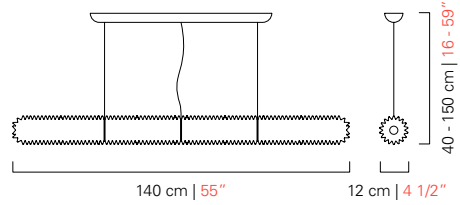

texture completamente diverse condividono una comune ispirazione su forme e volumi. Tre le opzioni scelte per questo dialogo materico: oro spazzolato, rame spazzolato e nichel nero spazzolato, tre finiture raffinate e di tendenza. Le sospensioni Opéra sono disponibili in tre diverse varianti dimensionali, per sposare progetti di interior design di natura e portata differente: dagli spazi domestici fino ai grandi ambienti di rappresentanza e contract, dove è possibile realizzare delle vere e proprie installazioni personalizzate, con composizioni asimmetriche e multiformi. La versione applique si sviluppa in senso verticale ed è perfetta per valorizzare una parete e punteggiarla di accenti luminosi. Il modello da tavolo presenta un'estetica ancora più avvolgente, capace di creare, anche da spenta, un'atmosfera calda e preziosa.

*and support the luminous volumes: completely different textures, sharing a specific inspiration in their shapes and substance. Three options have been selected for this dialogue of materials: brushed gold, brushed copper and brushed black nickel, for three refined, trendsetting finishes. The Opéra suspension lamps come in three different sizes, ready to be utilized in interior design projects of different types and scales: from residential spaces to contract applications, where it is possible to organize true custom installations, with asymmetrical and multiform compositions. The wall sconce version develops vertically and is perfect to enhance walls, punctuating them with luminous accents. The table model has an even more enveloping look, and is able to create a warm, precious atmosphere even when the lamp is off.*

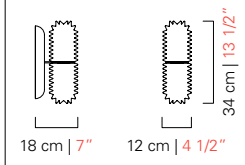
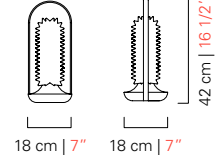
<b>Modelli e misure</b> <i>Models and sizes</i>	Opéra	
	<b>7386-00</b>	<b>7387-00</b>
		
<b>Peso</b> <b>Weight</b>	12 kg 26 lb	15 kg 33 lb
<b>Lampadine</b> N. Tipo W max. <b>Bulbs</b> N. Type W max.	1 Strip Led 30 30	1 Strip Led 38 38
<b>Dimmerabile</b> <b>Dimmable</b>	D	D
<b>Lampadine include</b> <b>Bulbs included</b>	Strip Led	Strip Led
<b>Certificazioni</b> <b>Certification Marks</b>		

<b>Modelli e misure</b> <i>Models and sizes</i>	Opéra	
	<b>7388-00</b>	
		
<b>Peso</b> <b>Weight</b>	18 kg 40 lb	
<b>Lampadine</b> N. Tipo W max. <b>Bulbs</b> N. Type W max.	1 Strip Led 45 45	
<b>Dimmerabile</b> <b>Dimmable</b>	D	
<b>Lampadine include</b> <b>Bulbs included</b>	Strip Led	
<b>Certificazioni</b> <b>Certification Marks</b>		

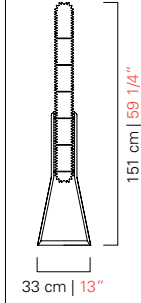
<b>Modelli e misure</b> <i>Models and sizes</i>	Opéra	
	<b>7389-00</b>	<b>7391-00</b>
		
<b>Peso</b> <b>Weight</b>	6 kg 13 lb	8 kg 18 lb
<b>Lampadine</b> N. Tipo W max. <b>Bulbs</b> N. Type W max.	1 Strip Led 12 12	1 Strip Led 10 Strip Led 10
<b>Dimmerabile</b> <b>Dimmable</b>	D	D Not dimmable for the USA version
<b>Lampadine include</b> <b>Bulbs included</b>	Strip Led	Strip Led
<b>Certificazioni</b> <b>Certification Marks</b>		

<b>Modelli e misure</b> <i>Models and sizes</i>	Opéra	
	<b>7392-00</b>	
		
<b>Peso</b> <b>Weight</b>	25 kg 55 lb	
<b>Lampadine</b> N. Tipo W max. <b>Bulbs</b> N. Type W max.	1 Strip Led 32 Strip Led 32	
<b>Dimmerabile</b> <b>Dimmable</b>	D	
<b>Lampadine include</b> <b>Bulbs included</b>	Strip Led	
<b>Certificazioni</b> <b>Certification Marks</b>		



**Colori disponibili**

*Available colours*



**CC**  
Cristallo  
*Crystal*

**Finiture**

*Finishings*



**NJ**  
Nichel Nero  
Spazzolato  
*Brushed Black  
Nickel*



**OJ**  
Oro Spazzolato  
*Brushed Gold*

**Colori bespoke**

*Bespoke colours*



**IC**  
Grigio  
*Grey*



**EK**  
Sabbia  
*Sand*



**FM**  
Fumé  
*Smoke*



**CG**  
Cognac  
*Cognac*



**OO**  
Oro  
*Gold*



**DK**  
Oliva  
*Olive*



**EL**  
Cedro Liquido  
*Liquid Citron*



**CK**  
Pervinca  
*Periwinkle*



**AM**  
Ametista  
*Amethyst*



**RS**  
Rosé  
*Light Pink*



**AK**  
Blu Cadetto  
*Cadet Blue*



**AQ**  
Acquamare  
*Aquamarine*



**BL**  
Bluino  
*Light Blue*



**FK**  
Indaco  
*Indigo*







## ENLIGHTENING UNIQUENESS

In sette secoli di storia abbiamo visto mode andare e venire. Alcune minimaliste, altre più barocche, ma tutte ugualmente prese ad inseguire il tempo che passa, nella disperata ricerca del "nuovo".

*In seven centuries of history, we have seen fashions come and go. Some were minimal, others more baroque, but every one of them chased time in a desperate search for the "new."*

A Venezia il tempo, invece, scorre lento. Non c'è fretta, solo tempo e spazio necessari per affinare un'arte.

*Time in Venice, instead, goes by slowly. There is no rush, no craze, just a great deal of space and time to develop your craft.*

Così, abbiamo deciso di prenderci il nostro tempo, per fare qualcosa di unico e originale. Qualcosa che possa durare per sempre. Qualcosa che vada oltre il fascino effimero di una stagione.

*So we took our time and in that time we have learned that we would rather do something unique and enlightening that lasts forever instead of something new that only fascinates you for one season.*

Ci vuole forza per plasmare il vetro dalla sabbia e dal fuoco. Ci vuole pazienza per arrivare alla forma perfetta senza compromessi e ci vuole cuore, tanto cuore, per portare una tradizione leggendaria di illuminazione di lusso fino ai giorni nostri, in un perfetto equilibrio tra passato, presente e futuro.

*It takes strength to bring glass out from the fire and heat. It takes patience to strive for nothing less than the perfect shape. And it takes heart, a lot of it, to grow a legendary luxury lighting tradition into the new world, working with innovators and traditionalists alike.*

Ma ancora una volta possiamo permetterci il lusso del tempo. E forse, anche voi.

*But again, we can afford the luxury of time. And perhaps, so can you.*

## VENETIAN CRYSTAL



Le creazioni Barovier&Toso sono opere uniche, in Cristallo Veneziano soffiato a bocca e realizzate a mano da maestri vetrai di Murano, depositari di una tradizione secolare che solca la storia da generazioni.

È ad Angelo Barovier che si deve l'invenzione di una rivoluzionaria formula che permise di ottenere un materiale inedito, dalle straordinarie caratteristiche di estrema trasparenza e brillantezza. Fu con decreto della Repubblica di Venezia, intorno al 1455, che Angelo Barovier ottenne addirittura l'esclusiva nella produzione del "Cristallo Veneziano". Ciò che ancora oggi rende unica quella ricetta materica, giunta fino a noi e ulteriormente perfezionata, è la totale assenza di piombo e arsenico. Questo distingue il nostro Cristallo Veneziano da qualunque altro cristallo in commercio e rende la tecnica del cristallo soffiato, come anche tutto il processo produttivo, eseguibile in totale sicurezza da parte dei maestri vetrai.

Il Cristallo Veneziano è un materiale unico, sostenibile e sicuro, capace di dar forma ad opere di grande valore artistico, le creazioni Barovier&Toso.

*The creations of Barovier&Toso are one-of-a-kind works in Venetian mouth blown Crystal and hand crafted by master artisans in Murano, custodians of an age-old tradition passed down across the generations.*

*Angelo Barovier invented a revolutionary formula that made it possible to obtain an unprecedented material with extraordinary characteristics of extreme transparency and brightness. Thanks to a decree issued by the Republic of Venice in 1455, Angelo Barovier was granted the exclusive right to produce "Cristallo Veneziano" (Venetian Crystal). The factor that makes this formula unique, still used today through progressive refinements, is the total absence of lead and arsenic. This is what makes our Venetian Crystal different from any other crystal on the market, enabling the master artisans to carry out the entire production process in complete safety, achieving exceptional results.*

*The Venetian Crystal is a unique, sustainable and safe material, ideal to give form to works of great artistic value: the creations of Barovier&Toso. Barovier&Toso produces exclusively Venetian Crystal.*



Barovier&Toso



baroviertoso



Barovier&Toso



Barovier&Toso



Barovier&Toso



**Barovier&Toso**  
**Vetriere Artistiche Riunite srl**

**Headquarter**

Fondamenta Vetrai 28  
30141 Murano Venice | Italy  
T. (+39) 041 739 049  
info@barovier.com

**Marketing Office**

Via Durini 5  
20122 Milan | Italy  
T. (+39) 02 778 78 600  
press@barovier.com

**Palazzo Barovier&Toso**

Fondamenta Manin 1/D  
30141 Murano Venice | Italy  
palazzo@barovier.com

**Milan Showroom**

Via Durini 5  
20122 Milan | Italy  
showroom.milano@barovier.com

**Venice Showroom**

San Marco 2424  
30124 Venice | Italy  
showroom.venezia@barovier.com

***barovier.com***

**Photo Credits**

Ginori 1735  
Maurizio Cavallasca  
Morgan Norman  
Studio Pointer

*Print 04.2023*



*barovier.com*