

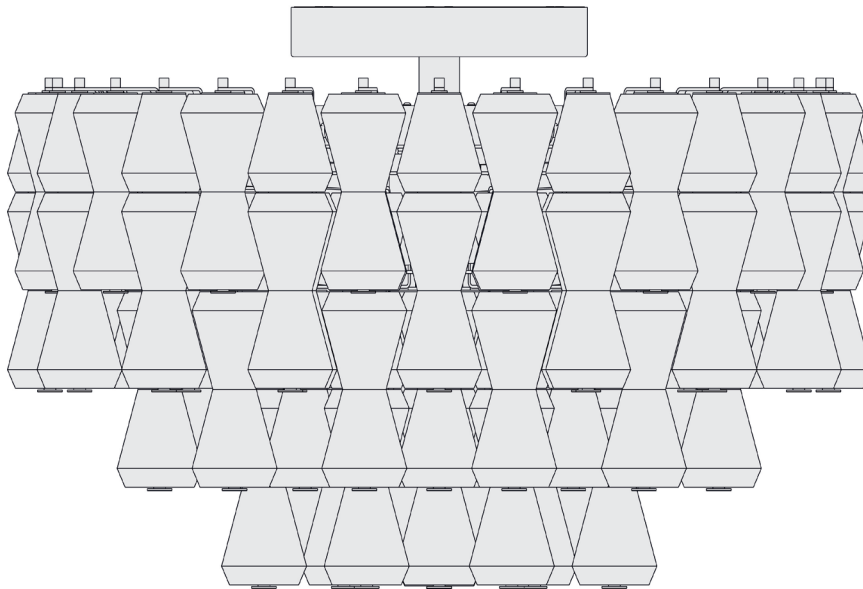

# Barovier&Toso





VENEZIA 1295



Plafoniera  
*Ceiling lamp*

**CLEPSYDRA**  
**7476**



<b>DATI TECNICI - TECHNICAL DATA</b>		
Prodotto <i>Product</i>	Plafoniera <i>Ceiling lamp</i>	
Installazione <i>Installation</i>	Fissaggio a soffitto <i>Ceiling fixture</i>	
Altezza <i>Height</i>	59 cm - 45 1/4"	
Diametro <i>Diameter</i>	85 cm - 33 1/2"	
Peso stimato <i>Estimated weight</i>	95 kg - 209 lb	
<b>DATI ELETTRICI - ELECTRICAL DATA</b>		
Alimentazione <i>Power supply</i>	<input type="checkbox"/> 220-240V 50/60Hz	<input type="checkbox"/> 100-120V 50/60Hz
Lampadine <i>Light bulbs</i>	<input type="checkbox"/> 12 E14 max 40W	<input type="checkbox"/> 12 E14 max 40W
<b>MARCHI - MARKS</b>		
	Le lampade sono state sottoposte alle prove di sicurezza elettrica richieste dalle norme europee EN 60 598-1, corrispondenti alle norme italiane CEI 34 -21, norme per la sicurezza elettrica. <i>The lamps were subject to the electric safety tests required by the European standards EN 60 598-1, correspondent to the Italian standards CEI 34 -21, electric safety standards.</i>	
	Apparecchio idoneo ad essere installato su superfici normalmente infiammabili. <i>Apparatus suitable to be installed on normally inflammable surfaces.</i>	
<b>CL. I</b>	Componente dotato di isolamento principale provvisto di un dispositivo per il collegamento delle masse a un conduttore di protezione (messa a terra). <i>Component equipped with main isolation provided with a device for the connection of the masses to a safety conductor (earthing).</i>	
	Marchio UL, valido solo per prodotti destinati al mercato nord americano. Prodotto conforme alla normativa UL 1598 <i>UL Mark, valid just for North American products. Product complying with the standard UL 1598.</i>	
	Apparecchio di illuminazione con sorgente luminosa dimmerabili. <i>Luminaire with dimmable light source.</i>	
<b>COLLAUDO - TEST</b>		
Collaudato da: <i>Tested by:</i>		
Data: <i>Date:</i>		

## ISTRUZIONI DI MONTAGGIO

Riferimento immagini alle pagine seguenti

### ATTENZIONE!

Togliere la corrente prima di eseguire qualsiasi collegamento elettrico o sostituire le lampadine.

- 1 Fisare la piastra **A** a soffitto.
- 2 Agganciare la struttura **B** alla piastra **A** e stringere i dadi.
- 3 Assicurarsi di aver tolto la tensione, quindi effettuare i collegamenti elettrici con la linea di rete.
- 4 Chiudere il rosone bloccando le apposite viti
- 5 Montare i vetri secondo lo schema. Se presenti, distribuire 1 vetro colorato ogni 2 cristallo, o in alternativa secondo il proprio gusto.



Se il cavo flessibile di questo apparecchio viene danneggiato, deve essere sostituito da personale qualificato al fine di evitare pericoli

## MOUNTING INSTRUCTIONS

*Images reference at the following pages*

### WARNING

**Switch off the current before connecting or relamping.**

#### USA ONLY

**RISK OF FIRE AND ELECTRIC SHOCK. THIS PRODUCT IS TO BE INSTALLED BY A QUALIFIED ELECTRICIAN ONLY. DO NOT ATTACH TO OUTLET BOX, IF FIXTURE IS OVER 50 POUNDS!**

- 1 *Fix plate **A** to the ceiling.*
- 2 *Mount the fixture **B** to plate **A** and fasten the nuts.*
- 3 *Make sure to have turned off the power and then make the connections with the power supply line of the system.*
- 4 *Close the canopy and fasten the proper screws.*
- 5 *Fix the glasses following the scheme. If provided, place 1 colored glass each 2 crista, or as an alternative according to your taste.*



*If the external cable or cord is damaged, it shall be exclusively replaced by a qualified person in order to avoid a hazard.*



## SCHEMA DI MONTAGGIO - ASSEMBLING SCHEME

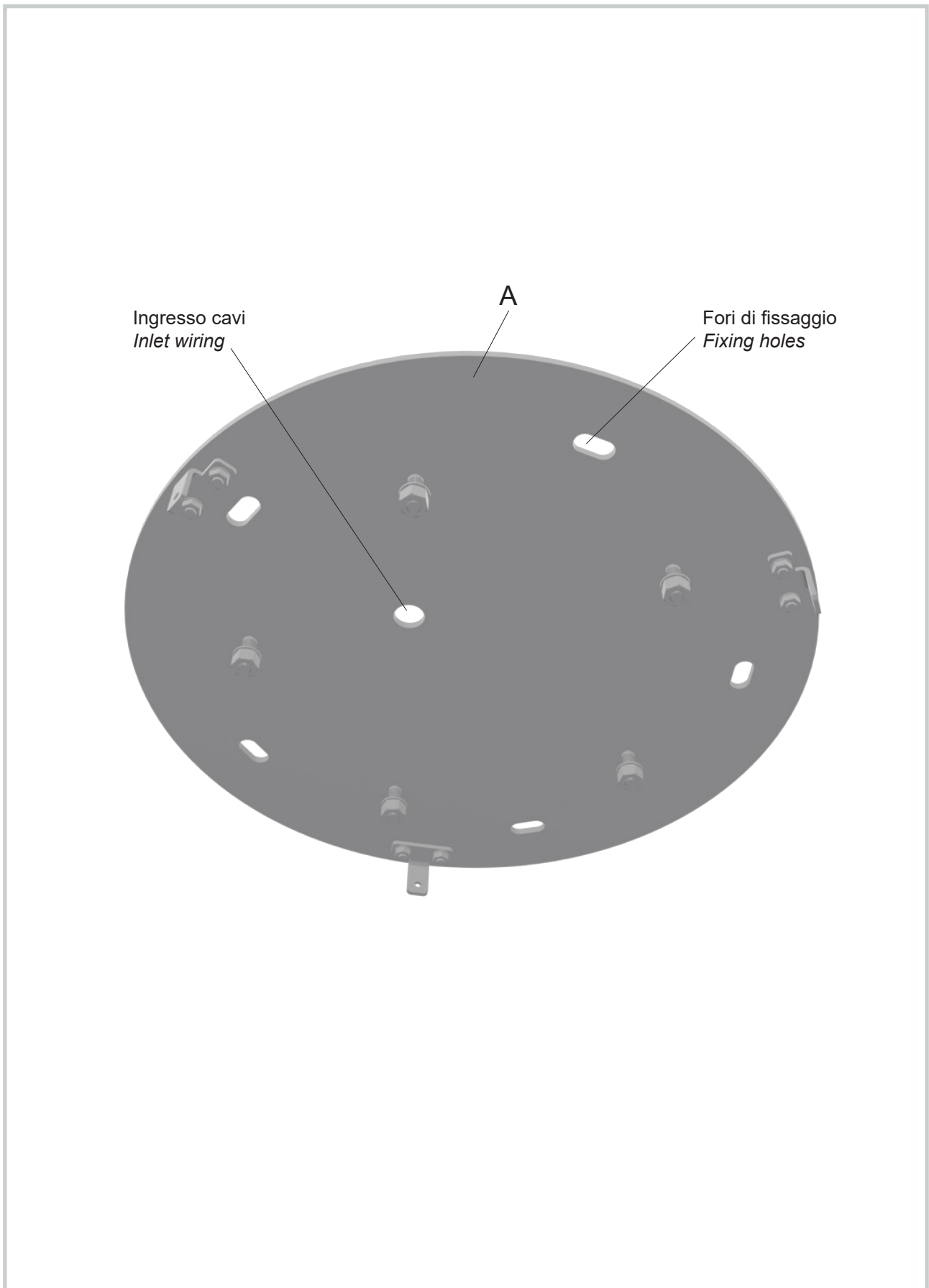

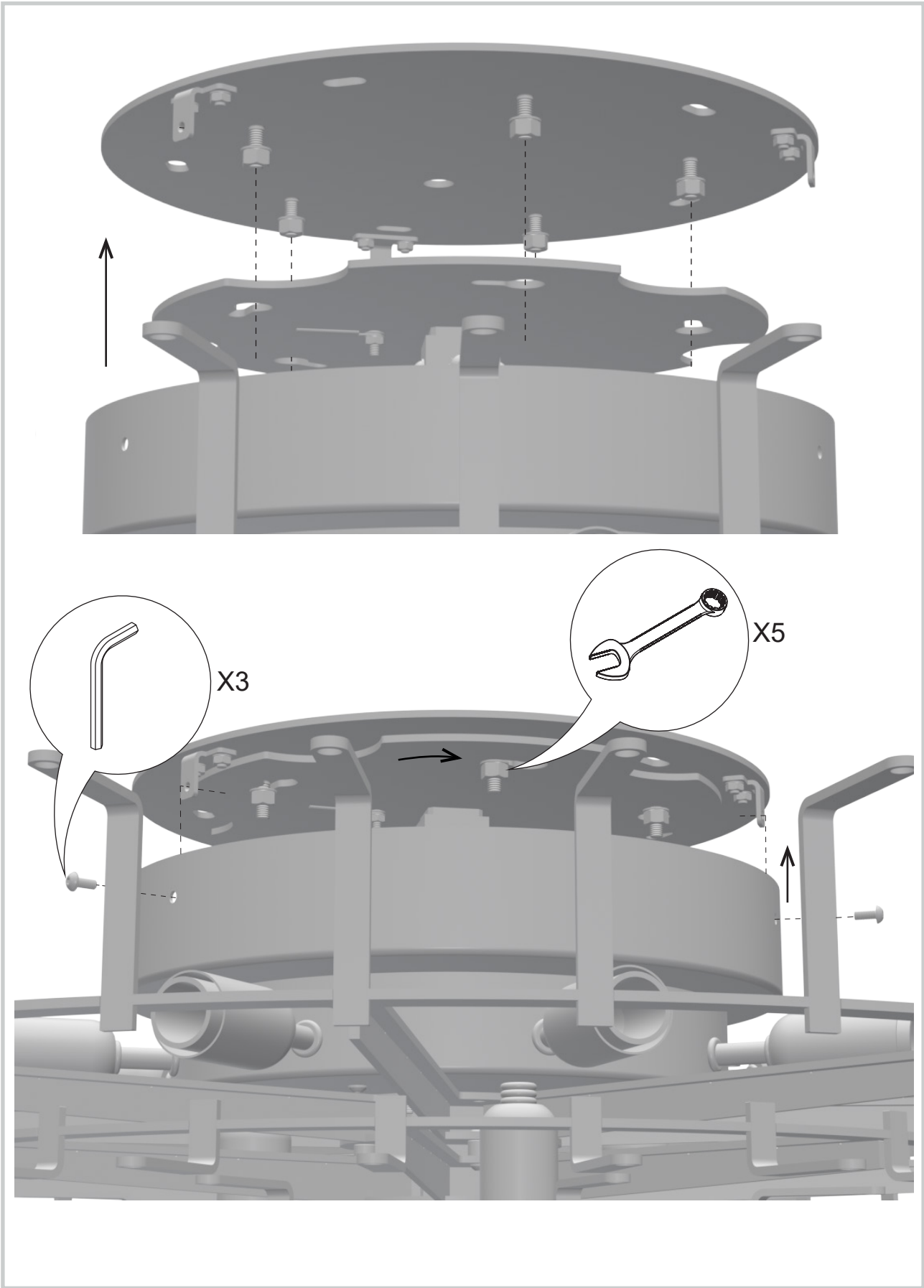



## SCHEMA DI MONTAGGIO - ASSEMBLING SCHEME



TIPO B

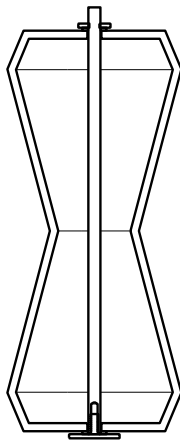

TIPO C

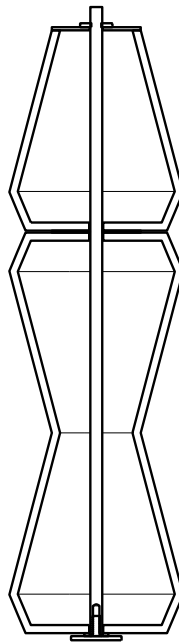

TIPO D

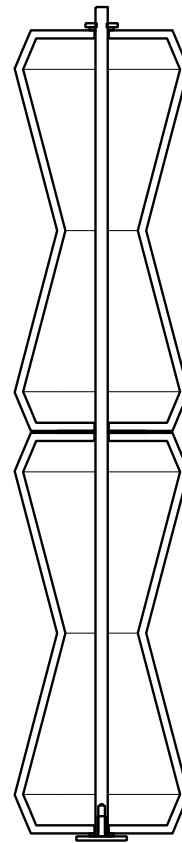



## SCHEMA DI MONTAGGIO - ASSEMBLING SCHEME

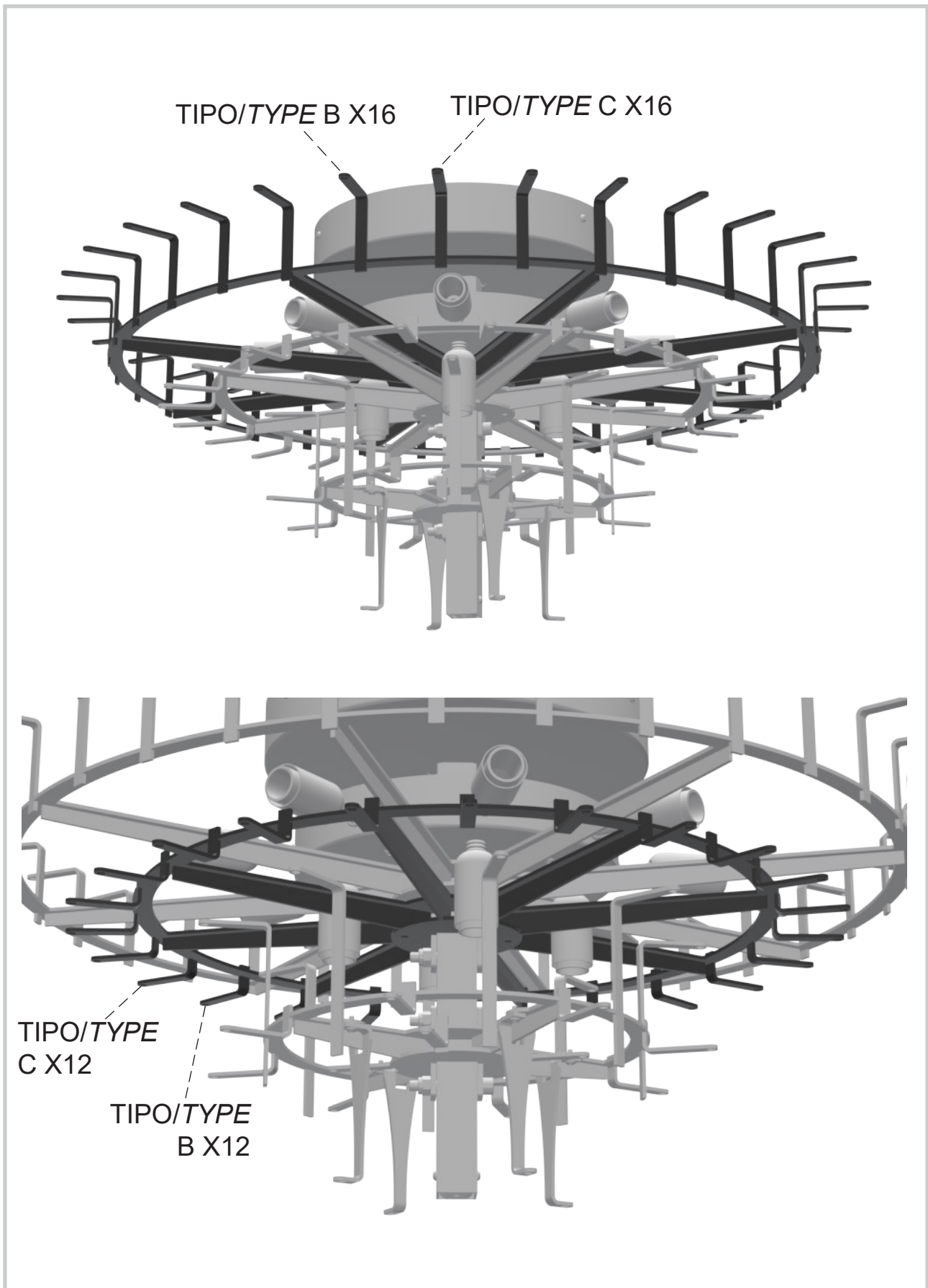



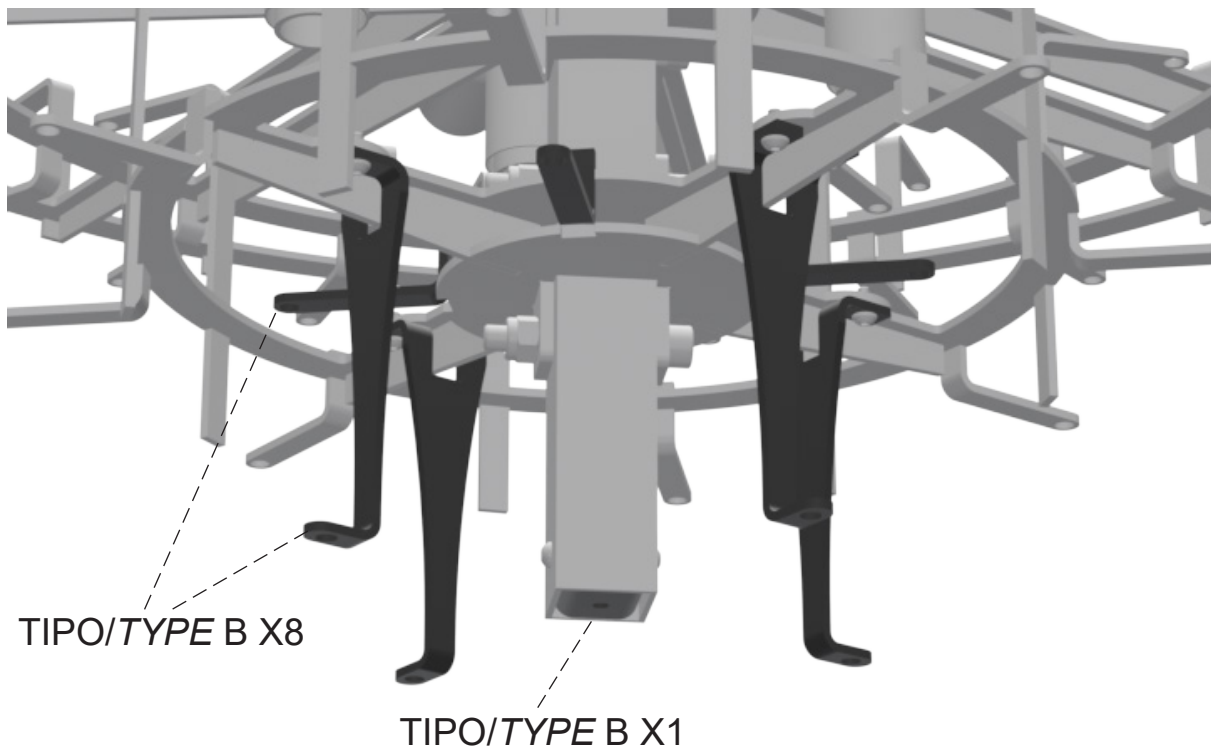
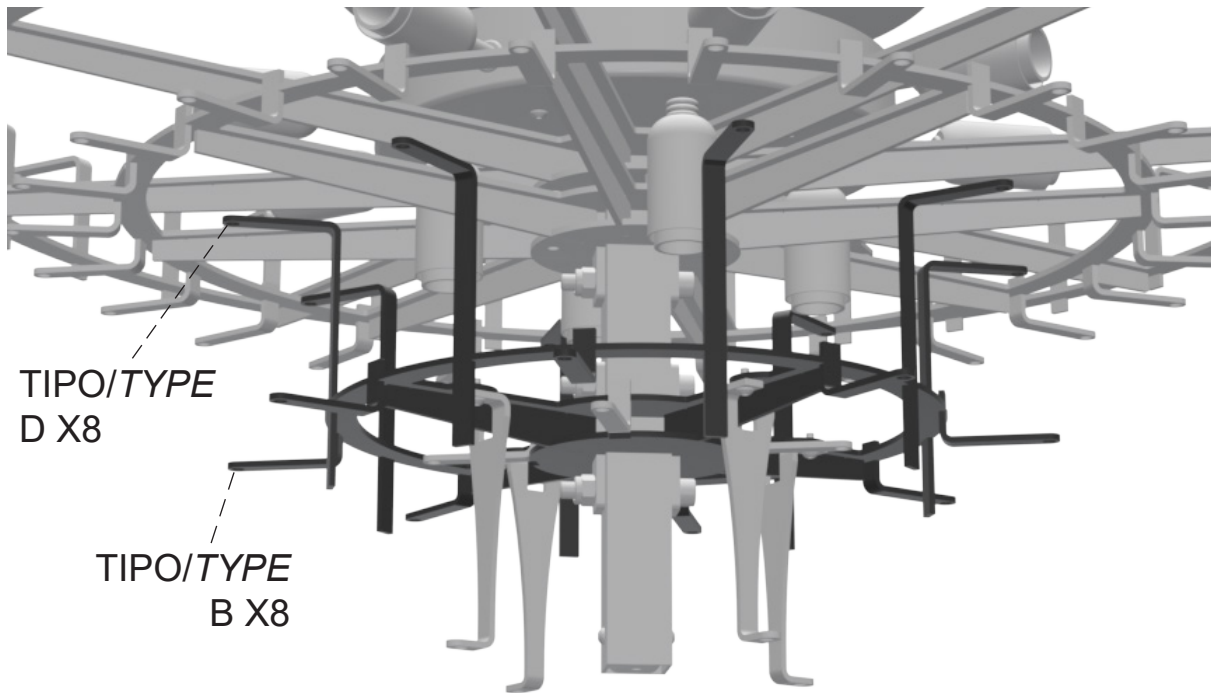



## SCHEMA ELETTRICO 220-240V - *CIRCUIT DIAGRAM 220-240V*

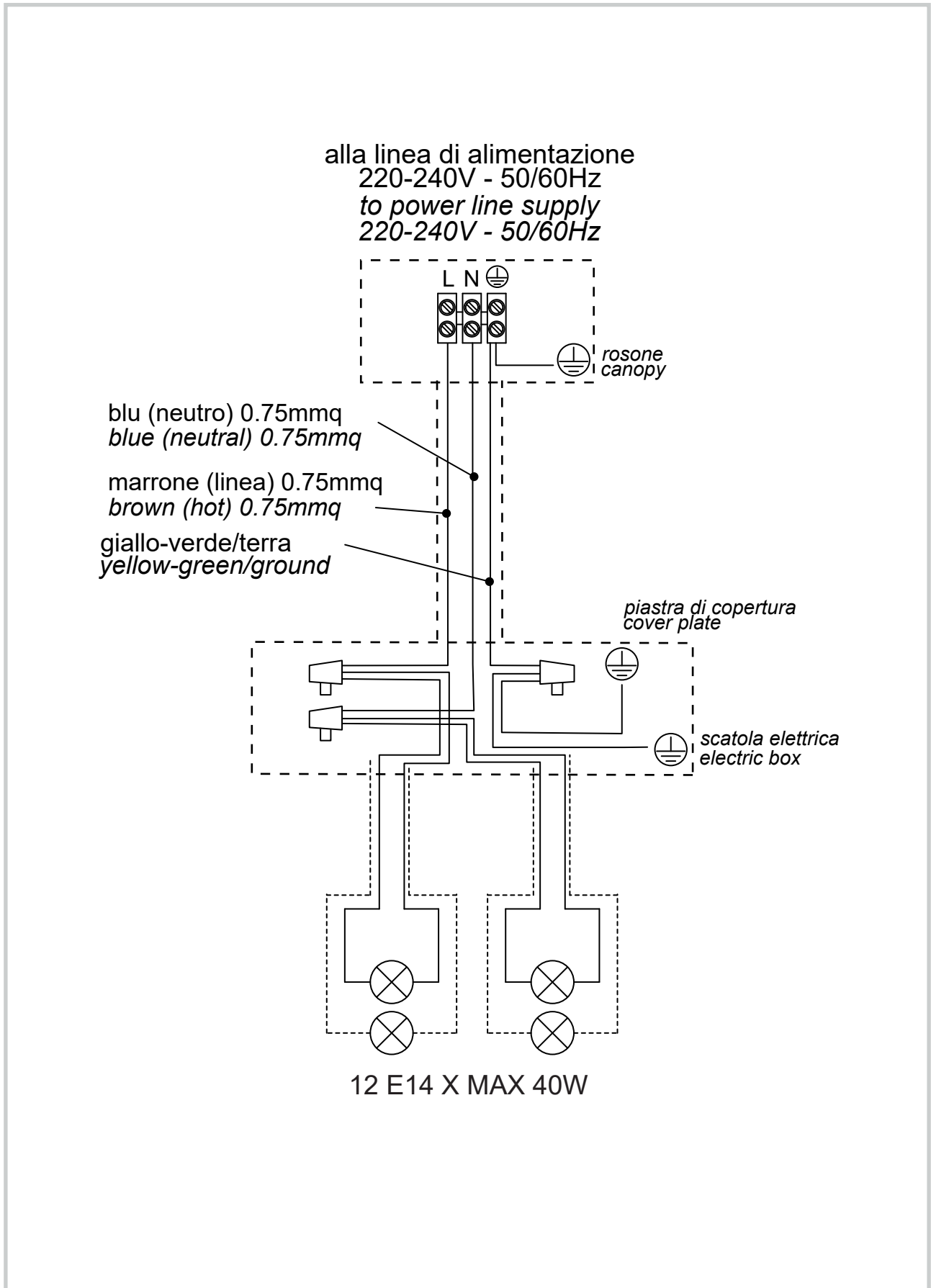

## SCHEMA ELETTRICO 100-120V - CIRCUIT DIAGRAM 100-120V

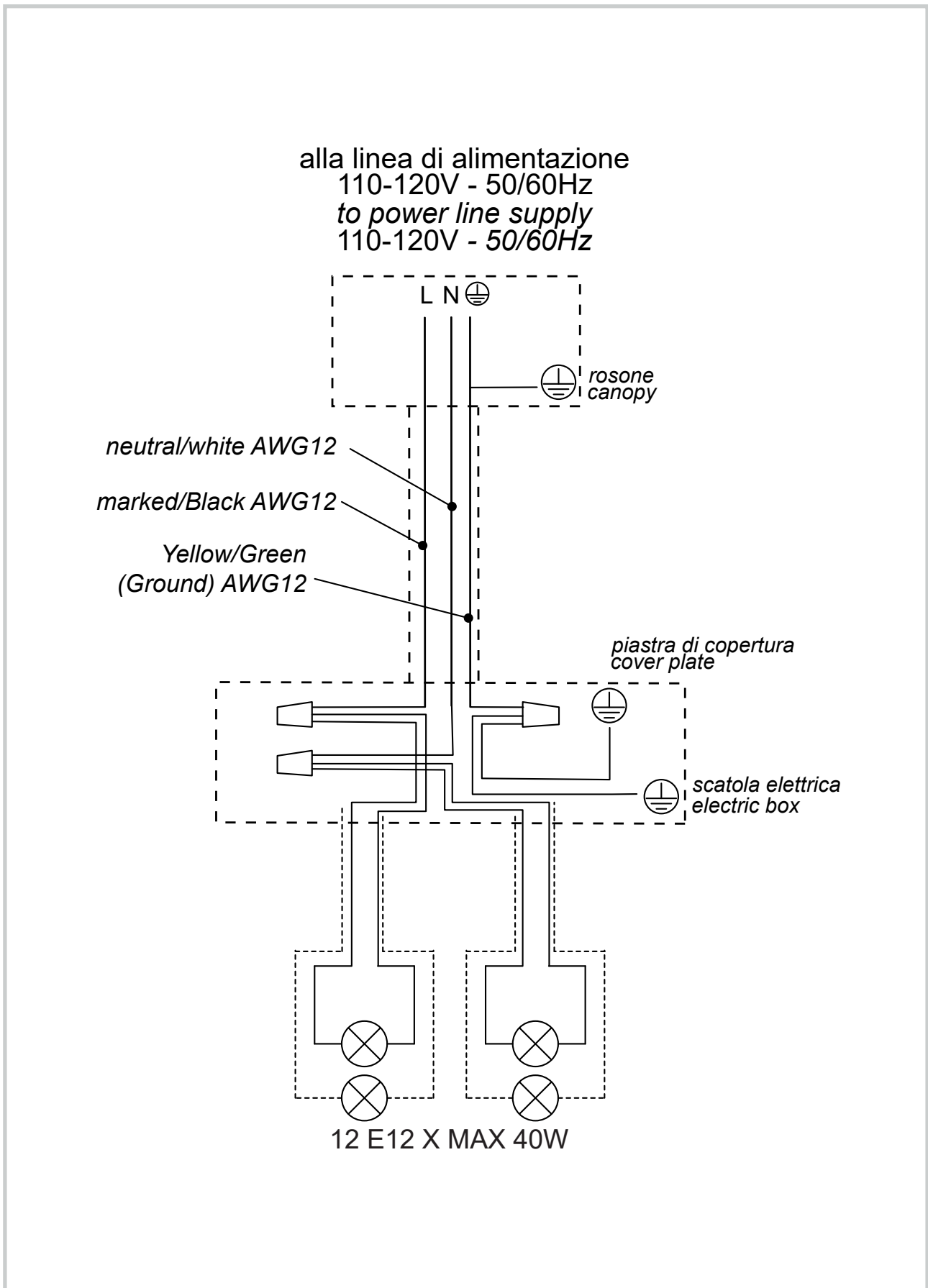



## COMPONENTI ELETTRICI - *ELECTRIC COMPONENTS*

PRODOTTI 220-240V - <i>PRODUCTS 220-240V</i>				
Prodotto <i>Item</i>	Tipo <i>Type</i>	Produttore <i>Manufacturer</i>	Codice <i>Code</i>	Dati tecnici <i>Technical data</i>
PORTALAMPADA <i>LAMPHOLDER</i>	E14	ARDITI	600/CI	2/250V - T190°C
MORSETTO <i>CONNECTING DEVICE</i>	SERRAGGIO INDIRETTO <i>INDIRECT CLAMPING</i>	CEMBRE	Z2.5-1	2,5 mmq - 450V T85°C
MORSETTO <i>CONNECTING DEVICE</i>	SERRAGGIO INDIRETTO <i>INDIRECT CLAMPING</i>	CEMBRE	Z6-1	6 mmq - 450V T85°C
MORSETTO <i>CONNECTING DEVICE</i>	SERRAGGIO INDIRETTO <i>INDIRECT CLAMPING</i>	CEMBRE	Z10-1	10 mmq - 450V T85°C
MORSETTO <i>CONNECTING DEVICE</i>	SERRAGGIO DIRETTO <i>DIRECT CLAMPING</i>	BM	991	1,5 mmq - 450V T85°C
MORSETTO <i>CONNECTING DEVICE</i>	SERRAGGIO DIRETTO <i>DIRECT CLAMPING</i>	BM	992	2,5 mmq - 450V T85°C
MORSETTO <i>CONNECTING DEVICE</i>	SERRAGGIO DIRETTO <i>DIRECT CLAMPING</i>	BM	9924	4 mmq - 450V T85°C
MORSETTO <i>CONNECTING DEVICE</i>	SERRAGGIO DIRETTO <i>DIRECT CLAMPING</i>	BM	993	6 mmq - 450V T85°C
MORSETTO <i>CONNECTING DEVICE</i>	SERRAGGIO DIRETTO <i>DIRECT CLAMPING</i>	BM	M093	4 mmq - 400V T150°C
MORSETTO <i>CONNECTING DEVICE</i>	SERRAGGIO DIRETTO <i>DIRECT CLAMPING</i>	IMET	B22	4 mmq - 450V T85°C
CONNETTORE RAPIDO <i>QUICK CONNECTOR</i>	1 POLO <i>1 POLE</i>	TYCO	1-480350-0 + 61118	0,5 / 2,00 mmq
CONNETTORE RAPIDO <i>QUICK CONNECTOR</i>	1 POLO <i>1 POLE</i>	TYCO	1-480349-0 + 61117	0,5 / 2,00 mmq
CABLAGGIO INTERNO <i>INTERNAL WIRING</i>	1 POLO <i>1 POLE</i>	SALCAVI	H05V-K	0,5 / 2,00 mmq
CABLAGGIO INTERNO <i>INTERNAL WIRING</i>	1 POLO <i>1 POLE</i>	SALCAVI	H05V2-K	0,5 / 2,00 mmq
CABLAGGIO INTERNO <i>INTERNAL WIRING</i>	1 POLO <i>1 POLE</i>	SALCAVI	H07V-K	1,50 / 6,00 mmq
CABLAGGIO INTERNO <i>INTERNAL WIRING</i>	1 POLO <i>1 POLE</i>	SALCAVI	SPT-1	1x0,75 mmq
CABLAGGIO INTERNO <i>INTERNAL WIRING</i>	1-2-3 POLI <i>1-2-3 POLES</i>	SALCAVI	H03VV-F	0,50 / 0,75 mmq
CABLAGGIO INTERNO <i>INTERNAL WIRING</i>	1-2-3 POLI <i>1-2-3 POLES</i>	SALCAVI	H05VV-F	0,75 / 4,00 mmq
CABLAGGIO INTERNO <i>INTERNAL WIRING</i>	2 POLI <i>2 POLES</i>	SALCAVI	SPT-1	AWG18
I componenti elettrici del prodotto possono essere diversi da quelli indicati in tabella ma con uguali caratteristiche tecniche e di sicurezza.				
The electric components of the product can be different from those listed but with the same technical and safety data.				

<b>PRODOTTI 100-120V - PRODUCTS 100-120V</b>				
<b>Prodotto Item</b>	<b>Tipo Type</b>	<b>Produttore Manufacturer</b>	<b>Codice Code</b>	<b>Dati tecnici Technical data</b>
PORTALAMPADA LAMPHOLDER	E12	ARDITI	A600	125V T150°C
MORSETTO CONNECTING DEVICE	WIRE-NUT	IDEAL	73B	600V T105°C
MORSETTO CONNECTING DEVICE	WIRE-NUT	IDEAL	74B	600V T105°C
MORSETTO CONNECTING DEVICE	WIRE-NUT	IDEAL	76B	600V T105°C
CABLAGGIO INTERNO INTERNAL WIRING	2 POLI 2 POLES	SALCAVI	SPT1	AWG18
CABLAGGIO INTERNO INTERNAL WIRING	2-3 POLI 2-3 POLES	SALCAVI	SPT2	AWG18
CABLAGGIO INTERNO INTERNAL WIRING	1 POLO 1 POLE	SALCAVI	AWM 1015	AWG18 / AWG12
<p>I componenti elettrici del prodotto possono essere diversi da quelli indicati in tabella ma con uguali caratteristiche tecniche e di sicurezza.</p> <p>The electric components of the product can be different from those listed but with the same technical and safety data.</p>				







## COPYRIGHT

Il materiale riportato in questo catalogo e il catalogo stesso sono tutelati dalle leggi sui diritti relativi al copyright, ai marchi commerciali e/o su altri diritti di proprietà intellettuale. Detto materiale è di proprietà di Barovier&Toso Vetreterie Artistiche Riunite srl o delle sue controllate o consociate. Il suddetto materiale comprende, a titolo meramente esemplificativo, fotografie, immagini, illustrazioni, testo, disegni, logo, marchi commerciali, veste commerciale ed eventuale altro materiale contenuto nel catalogo. Tutti i diritti riservati.

È vietata la registrazione, memorizzazione, moltiplicazione in copie, riproduzione, ulteriore pubblicazione, esposizione, esibizione, trasmissione, distribuzione, trasferimento, traduzione, trasposizione, modifica, anche parziale, di tali contenuti (consistano essi in informazioni, grafica, testi, immagini e qualsiasi altra espressione creativa) in qualsiasi forma e con qualsiasi mezzo (elettronico, meccanico, telematico, a mezzo di fotocopie, stampe, microfilm, registrazioni su qualsiasi supporto magnetico - incluso il CD-ROM - o altro), salvo preventiva e specifica autorizzazione da parte di Barovier&Toso Vetreterie Artistiche Riunite srl. Qualora venga concessa la preventiva autorizzazione scritta alla riproduzione, è fatto comunque obbligo di citarne la fonte.

## COPYRIGHT

*All materials on this catalogue and the catalogue itself, are protected by copyrights, trademarks and/or other intellectual property rights. These materials are owned by Barovier&Toso Vetreterie Artistiche Riunite srl or its subsidiaries or affiliates. Such materials include, but are not limited to, the photographs, images, illustrations, text, designs, logos, trademarks and other materials contained in this catalogue. All rights are reserved, worldwide.*

*You may not record, store, copy, reproduce, republish, publicly exhibit, post, transmit, distribute, transfer, translate, transpose, modify, in whole or in part, any such material (information, artwork, text, pictures and the like), in any form or by any electronic, mechanical, photocopying, recording or any other means (including CD-ROM) without first obtaining the case-by-case prior consent of Barovier&Toso Vetreterie Artistiche Riunite srl.*

*When the reproduction has been previously authorized, the use is permitted only if the source for the material has been clearly stated.*

## УВЕДОМЛЕНИЕ ОБ АВТОРСКИХ ПРАВАХ

Материал, приведенный в этом каталоге, и сам каталог защищены законами об авторских правах, торговых марках и/или других правах, относящихся к интеллектуальной собственности.

Данный материал является собственностью

фирмы Barovier&Toso Vetreterie Artistiche Riunite srl, либо подконтрольным ей или дочерним структурам. Вышеуказанный материал содержит, исключительно в качестве примера, фотографии, изображения, иллюстрации, текст, рисунки, логотипы, торговые марки, коммерческое оформление и другой возможный материал, включенный в каталог. Все права на этот материал защищены.

Запрещены запись, сохранение на носителе, тиражирование копий, воспроизведение, дальнейшая публикация, экспозиция, показ, передача, сбыт, уступка, перевод, перемещение, изменение, в том числе частичное, содержимого данных материалов (состоят ли они в информации, графике, текстах, изображениях или любой иной форме творческого выражения) в любой форме и при помощи любых средств (электронных, механических, телеинформационных, посредством фотокопий, печати, микрофильмов, записи на любой магнитный носитель, включая компакт-диски и прочее), за исключением случаев предварительного и специального разрешения со стороны фирмы Barovier&Toso Vetreterie Artistiche Riunite srl.

В случае получения предварительного письменного разрешения на воспроизведение данного материала, следует обязательно указать его источник.

## 版权声明

本目录所有的内容包括目录本身都受版权法，商标法规与/或其他相关知识产权的保护。

此内容的版权属 柏華 (Barovier&Toso) 有限公司及其下属公司或其共同集团公司所有。

所指内容包括，仅举例说明，照片，图片，插图，文字，标示，标志，商标，商业版面设计及其他本目录中所涉及的内容。

均为专属权利。

任何人不得翻录，储存，多份复制，转载，发行，表演，展示，传播，散布，播送，翻译，变更，改动，及局部摘编此内容（包括获取资料，图表，文字，图片及其他任何具有创造性的内容）禁止任何形式任何工具的传播（包括通过电子，机械，远程系统，复印件，印刷品，缩微胶卷，在任何种类磁带上的录音，包括光盘及其他），除非经 柏華 (Barovier&Toso) 有限公司正式预先许可。

在经取得正式书面许可复制的情况下，也必须注明其内容的出处来源。